

RenovaRP[®]

Paracentesis Kit

Instructions For Use

INDICATIONS FOR USE

The GI Supply RenovaRP[®] Paracentesis Kit is intended to be used in conjunction with the GI Supply RenovaRP[®] Paracentesis Pump and GI Supply RenovaRP[®] Fluid Drainage Bags to remove ascitic fluid from the abdominal cavity. The GI Supply RenovaRP Paracentesis Kit is intended to be used by medically trained healthcare professionals knowledgeable about paracentesis.

Note that the GI Supply RenovaRP Paracentesis Pump and GI Supply RenovaRP Fluid Drainage Bags are sold separately.

CONTRAINDICATIONS

Paracentesis procedures should not be performed on patients with clinically apparent disseminating intravascular coagulation and oozing from needle sticks or primary fibrinolysis until bleed risk is reduced. Paracentesis should not be performed on patients with a massive ileus with bowel distension unless the procedure is image guided.

WARNINGS

- The RenovaRP Paracentesis Kit is only intended for single use. Do not resterilize or reuse.
- Do not install the tube set in reverse orientation
- Do not use this product if package has been damaged or opened.
- The RenovaRP Paracentesis Kit is only intended for use with the RenovaRP Pump and RenovaRP Fluid Drainage Bags. Patient injury, operator injury and/or damage to

the RenovaRP Paracentesis Management System may occur if non RenovaRP products are used.

- Federal law restricts this device to sale by, or on the order of, a physician.

PRECAUTIONS

- Read and understand these Instructions for Use and the Operating Manual for the GI Supply RenovaRP Paracentesis Pump before use.
- Leaks may result if the RenovaRP Tube Set or RenovaRP Fluid Drainage Bags come in contact with sharps.
- It is recommended to use image-guided ultrasound to ensure correct catheter placement.
- Store at hospital room temperature 15° to 30°C (50° to 86°F).

DESCRIPTION

This RenovaRP[®] Paracentesis Kit contains:

- (1) RenovaRP[®] Tube Set
- (1) ChloroPrep[®] 3mL Applicator*
- (1) #11 Protected Safety Scalpel*
- (1) 18 Gauge x 1-1/2" (3.81cm) Needle*
- (1) 25 Gauge x 1-1/2" (3.81cm) Needle*
- (1) Luer Lock Syringe, 10mL
- (1) Luer Lock Syringe, 60mL
- (5) Gauze, 4" x 4", 6-ply*
- (1) Transparent Dressing, Suresite[®]
- (1) Fenestrated Drape with Tape
- (1) Foam Needle Block
- (1) Wrap, 30"x30"
- (1) One-Step[™] Centesis Catheter (valved)* (GIS-32 and GIS-33 Only)
- (1) Syringe Label (x2)

FIGURE 1

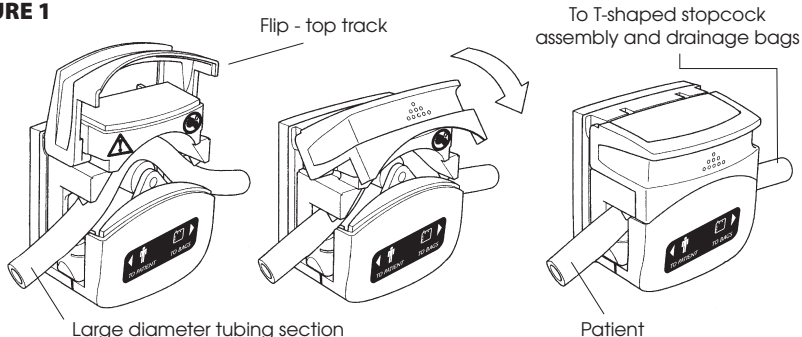

*Product is sterilized by manufacturer prior to assembly within kit package. See individual component package for sterility claim. ChloraPrep is a registered trademark of CareFusion 2200 Inc. Suresite is a registered trademark of Medline Industries. One-Step is a trademark of Merit Medical Systems Inc.

PUMP PREPARATION

CAUTION: be sure the RenovaRP[®] Paracentesis Pump is in standby mode before loading tubing into the pump. Serious injury may result if fingers are inserted into the pump rotor during operation.

Load the RenovaRP Tube Set into the RenovaRP Paracentesis Pump (Pump) by following the Pump Operating Manual.

- Lift the flip top track on the front of the Pump.
- Place the section of larger diameter tubing across the peristaltic pump head rotor.

CAUTION: ensure that the section of tubing leading from the patient enters the left side of the pump head and exits on the right side to the T-shaped stopcock assembly and fluid drainage bags. (See **Figure 1**)

- Lower the flip top track ensuring that the tubing is fitted correctly between the rollers and track and that there is no pinching of the tubing by the tube clamps. The tubing must lie naturally against the track and must not be twisted or stretched.
- Press the T-shaped stopcock assembly in the recessed area of the pump handle.
- Place two RenovaRP Fluid Drainage Bags on the posts located on each side of the pump.
- Attach the fluid drainage bags to the T-shaped stopcock assembly.
- Hand tighten all tubing connections to prevent leakage. (See **Figure 2**)

FIGURE 2

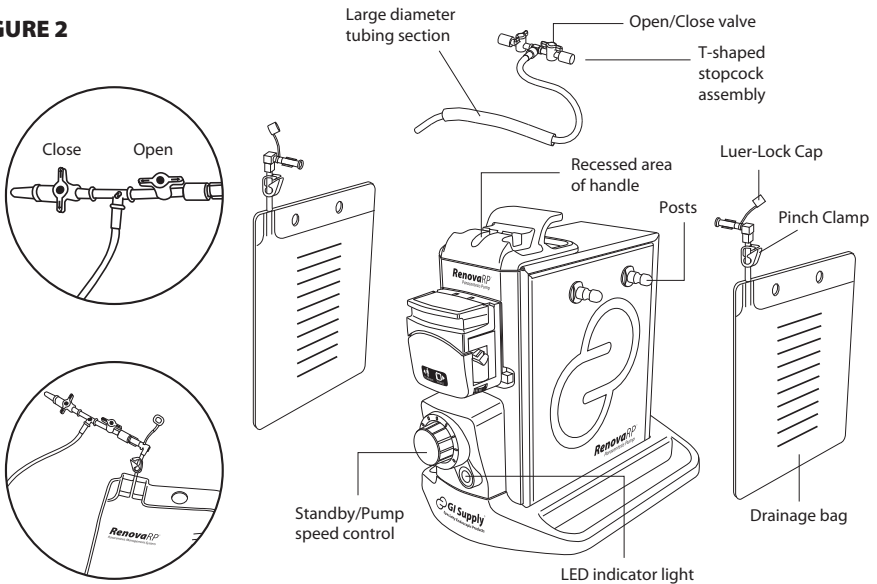

PATIENT PREPARATION

- Remove the RenovaRP Paracentesis Kit from the outside sterile packaging.
- Unwrap the RenovaRP Paracentesis Kit.
- Locate an appropriate paracentesis site on the abdomen. A lower quadrant is usually recommended.¹
- Prep skin at the puncture site per facility protocol. (ChloroPrep[®] is included in this kit.)
- Place the provided fenestrated drape over the puncture site.
- Anesthetize the skin, subcutaneous tissue and peritoneum at the puncture site per facility protocol.
- Make an incision at the puncture site to facilitate catheter penetration. 2-mm incision is usually sufficient. (A scalpel is included in this kit.)
- Using image-guided ultrasound, slowly insert the catheter into the incision site. When the catheter is in appropriate position remove the needle leaving the catheter in place.

 **CAUTION: CARE SHOULD BE TAKEN DURING INSERTION TO PREVENT UNINTENDED INJURY**

- The Z track insertion technique can reduce fluid leakage from the catheter insertion site.
- Aspiration can be used to confirm placement in the peritoneal cavity
- If a sample is needed for diagnostic studies, it may be removed directly from the catheter hub using the provided 60mL syringe.
- Attach the catheter to the RenovaRP Tube Set

PUMP OPERATION

- Ensure that both white pinch clamps are open on the RenovaRP Fluid Drainage Bags
- Ensure that one (1) of the blue stopcocks is in the OPEN position and that the other blue stopcock is CLOSED. (See Figure 2)
- Using the pump's speed control knob, turn on the pump to the desired speed.













BAG CHANGEOVER

- When a RenovaRP Fluid Drainage Bag is filled to the desired level, close the blue stopcock on the full bag side and open the blue stopcock on the empty bag side allowing ascitic fluid to flow into the alternate bag.
- Close the white pinch clamp on the bag to be removed.
- Detach the bag from the tube set and cap it with the provided cap.
- Remove bag from posts on the side of the pump
- If additional fluid is to be removed, continue replacing fluid drainage bags until the desired amount of ascitic fluid has been removed from the patient.
- When the paracentesis procedure is completed, withdraw the catheter and dress the site per facility protocol.

PROCEDURE COMPLETION

- Dispose of kit components and fluid drainage bags according to facility protocol and applicable regulations for biohazard waste and sharps.

SYMBOLS

-  Rx Only Federal law restricts this device to sale by, or on the order of, a physician
-  Consult Instructions for Use
-  Caution
-  Standby
-  Sterilized using Ethylene Oxide
-  Do not re-use
-  Does not contain natural rubber latex
-  Do Not Resterilize
-  Do not use if package is damaged
-  Use by date
-  Batch code
-  Catalogue Number
-  Manufacturer

¹ Firouzi M. Shah R.M., Roiz J. Gourgoutis R.O., Ultrasound guided large volume paracentesis Gastroenterology 1196; 110; A17



Manufactured for:

 GI Supply
Specialty Endoscopic Products

5069 Ritter Road, Suite 104, Mechanicsburg, PA 17055 USA
1-800-451-5797 • orders@gi-supply.com • www.gi-supply.com
RenovaRP is a registered trademark of GI Supply, Inc.