



SONESTA

PROCEDURE & EXAMINATION CHAIRS

WHEN QUALITY & DESIGN MEET TO CREATE
OUTSTANDING RESULTS



Innovation for Health

URINARY INCONTINENCE IS A SIGNIFICANT HEALTH PROBLEM WORLDWIDE

Between 2015 and 2030, the number of people aged 60 years or over is projected to grow by 56%.

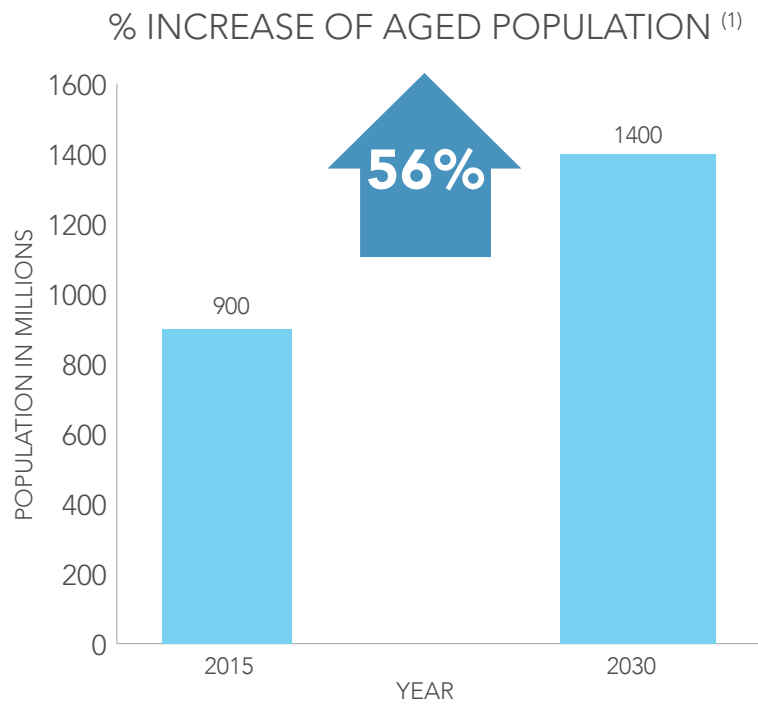

The number of individuals living with urinary incontinence is likely to increase as the population ages, since the prevalence increases by 25% with age.

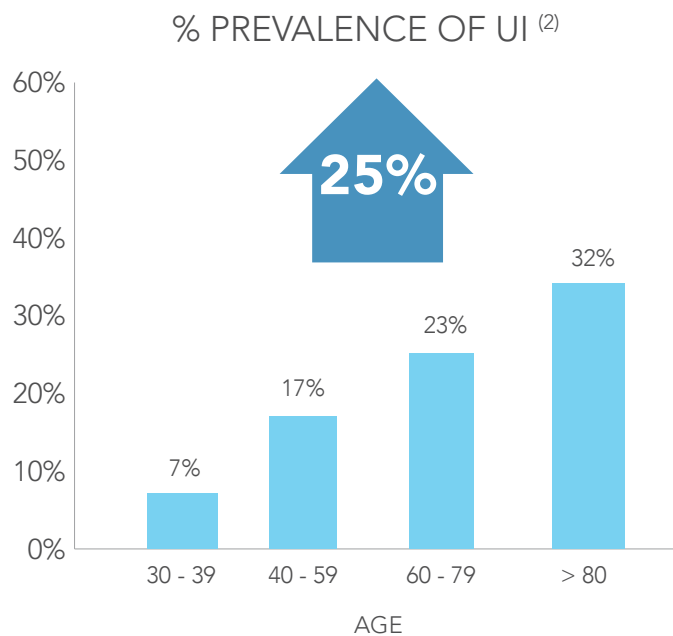

This growing population will need more diagnostic exams and procedures, and our Sonesta Tables are ready to help you handle the increasing volume of patients.

CLINICAL NEEDS & PREVALENCE

WHY CHOOSE SONESTA PROCEDURE & EXAMINATION CHAIRS?



Our specialty chairs:

- Provide easier access to and visualization of, the perineal area⁽³⁾
- Allow patient to remain in one place for preparation, filling and voiding phases of the urodynamic test⁽³⁾
- Eliminate the risk of catheters falling out or getting misplaced during transfer or ambulation⁽³⁾
- Rated IPX6 "protection against water incursion"

IDEAL SOLUTIONS FOR YOUR PRACTICE

	6210	S3	S2
Video-Urodynamics	•		
Gynecology Exams & Procedures	•	•	
Cystometry (CMG)	•	•	•
Pressure Flow Study	•	•	•
Urethral Pressure Profile (UPP)	•	•	•
Electromyography (EMG)	•	•	•
Anorectal Manometry	•	•	•

CLINICAL NEEDS & PREVALENCE

SONESTA 6210: FLUOROSCOPY PROCEDURE CHAIR

First and Only of its Kind



- The 6210 fluoroscopy procedure table offers the physician standing, seated and supine positioning capabilities
- This versatile table easily adjusts from/to standing, seated and supine positions via a hand held control, thus creating a table that is easily accessible to all patients



- The side mounted cantilevered design offers the physician anterior/posterior, lateral and oblique views without obstruction
- The superb C-arm access and a wide range of positioning possibilities make the 6210 the ideal table for any fluoroscopy procedure



- Radiolucent carbon fiber seat and back for head-to-toe imaging
- Four double wheel rolling casters offer unencumbered maneuverability

6210 SPECIFICATIONS

Length without foot rest/leg extension	156 cm.	63"
Length with foot rest/leg extension	196 cm.	78"
Width (total)	99 cm.	39"
Seat height with cushion (min.)	50 cm.	20"
Seat height with cushion (max.)	130 cm.	51"
Imaging area without foot rest/leg extension (length)	156 cm.	63"
Imaging area with foot rest/leg extension (length)	196 cm.	78"
Weight capacity	250 kg.	551 lbs.
Electrical	120/230V; 24VDC Output	
Meets EMC (Electromagnetic Compatibility) for IEC 60601		

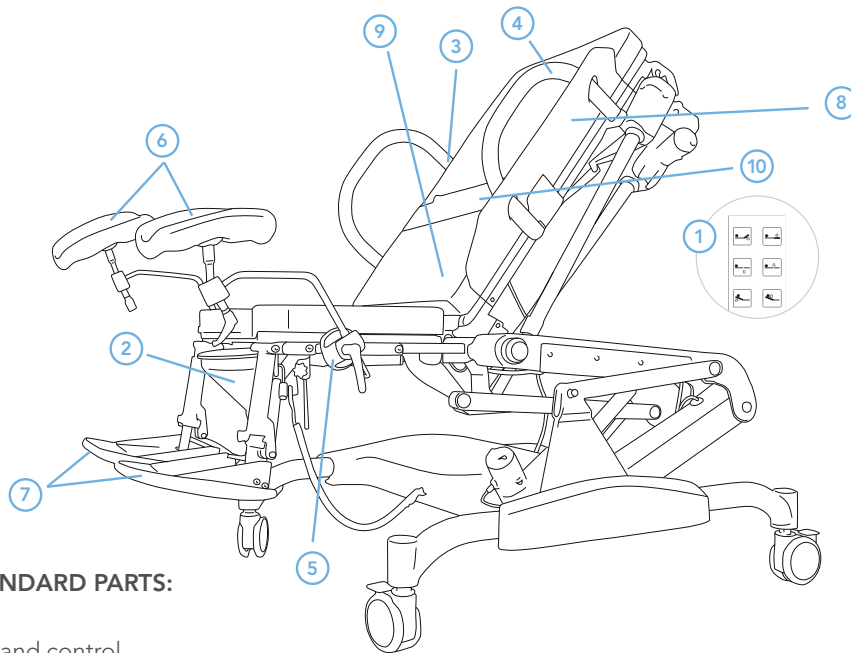

STANDARD PARTS:

- ① 1- Hand control
- ② 1- Plastic funnel w/ drainage
- ③ 1- Arm rest holder
- ④ 1- Arm rest
- ⑤ 2- Leg rest holders
- ⑥ 2- Heavy duty Rissler leg rests
- ⑦ 2- Fold up footrests
- ⑧ 1- Side rail
- ⑨ Mattress cushions
- ⑩ Restraint strap (optional)

6210

SONESTA S3: 3-MOTOR CHAIR

Designed Especially for You

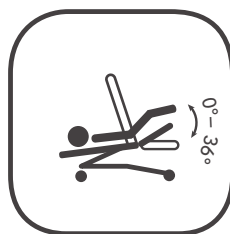

- Engineered ergonomics with improved foam to enhance patient comfort and feel
- One touch movement locking mechanism for precise positioning
- Three motors to control lift, reclining back and pelvic tilt
- Easy access for elderly and patients with physical difficulties
- Infinite height adjustment from 16" (40 cm) min. to 41" (105 cm) max.
- Lightweight and easy to move
- Supports up to 465 lbs. (210 kg) weight capacity

S3 SPECIFICATIONS

Length without extension cushions	143 cm.	56"
Length with extension cushions	193 cm.	76"
Width (total)	77 cm.	30"
Seat height with cushion (min.)	40 cm.	16"
Seat height with cushion (max.)	105 cm.	41"
Net weight	125 kg.	276 lbs.
Weight capacity	210 kg.	465 lbs.
Wheel diameter (2 lockable + 2 directional)	10 cm.	4"
Electrical	120/230V; 24VDC Output	
Meets EMC (Electromagnetic Compatibility) for IEC 60601		

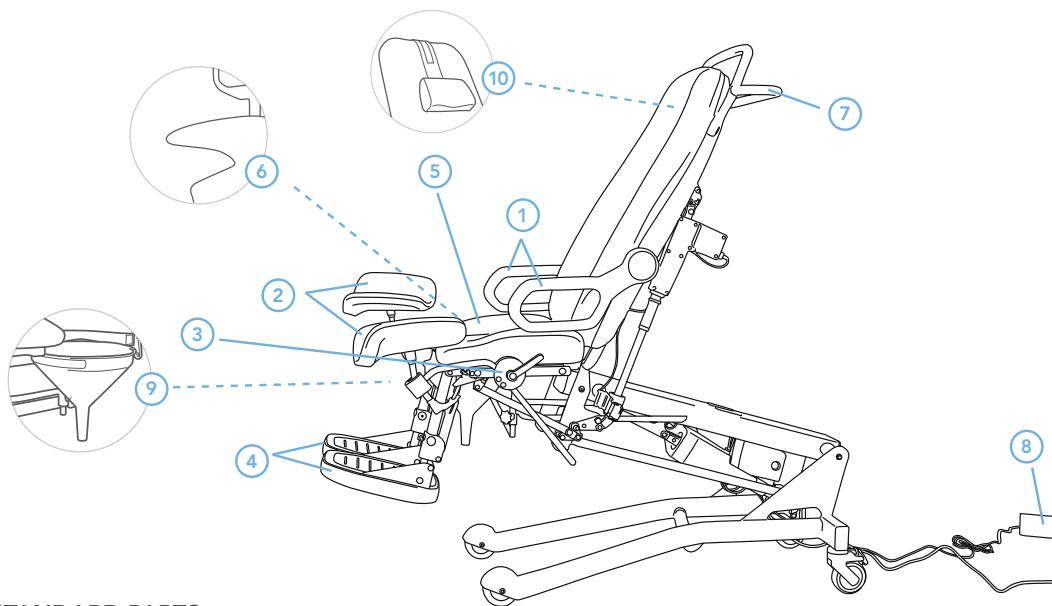

STANDARD PARTS:

- ① 2- Arm rests
- ② 2- Leg rests
- ③ 2- Leg rest holders
- ④ 2- Fold up footrests
- ⑤ 1- Seat cushion without cut out
- ⑥ 1- Cushion with cut out
- ⑦ 1- Paper towel holder + maneuvering handle
- ⑧ 1- Three motor foot control
- ⑨ 1- Funnel & funnel holder
- ⑩ 1- Neck pillow

SONESTA S2: 2-MOTOR CHAIR

The Right Tool to Facilitate Your Procedures



- Versatility
- Precise positioning
- Two motors are offered for lift and back tilt adjustments
- Easy access for the elderly and disabled
- Engineered ergonomics with improved foam to enhance patient comfort and feel
- Infinite height adjustments from 16" (40 cm) min. to 39" (100 cm) max.
- Lightweight and easy to move
- Supports up to 375 lbs. (170 kg) weight capacity

S2 SPECIFICATIONS

Length without extension cushions	143 cm.	56"
Length with extension cushions	193 cm.	76"
Width	77 cm.	30"
Seat height with cushion (min.)	40 cm.	16"
Seat height with cushion (max.)	100 cm.	39"
Net weight	100 kg.	220 lbs.
Lift capacity	170 kg.	375 lbs.
Wheel diameter (locking)	10 cm.	4"
Electrical	120/230V; 24VDC Output	
Meets EMC (Electromagnetic Compatibility) for IEC 60601		

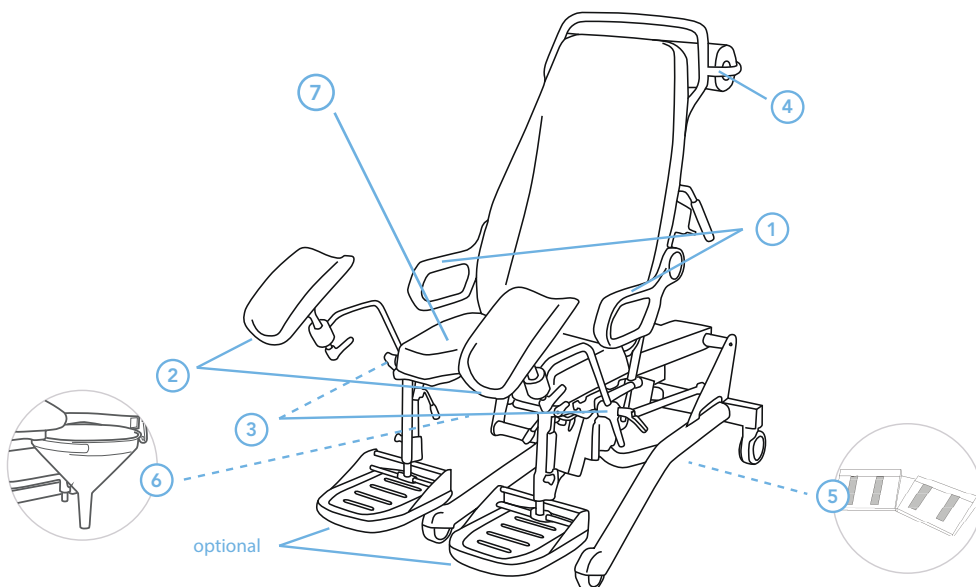

STANDARD PARTS:

- ① 2- Arm rests
- ② 2- Leg rests
- ③ 2- Leg rest holders
- ④ 1- Paper towel holder + maneuvering handle
- ⑤ 1- Two motor foot control
- ⑥ 1- Funnel & funnel holder
- ⑦ 1- Cushion with cut out

FEATURE COMPARISON CHART

	6210	S3	S2
Motorized height adjustment:	•	•	•
Motorized seat adjustment:	•	•	N/A
Motorized reclining back:	•	•	•
Length without extension cushions:	156 cm / 63"	143 cm / 56"	
Length with extension cushions:	196 cm / 78"	193 cm / 76"	
Width (Total):	99 cm / 39"	77 cm / 30"	
Seat height (Max.):	130 cm / 51"	105 cm / 41"	100 cm / 39"
Seat height (Min.):	50 cm / 20"	40 cm / 16"	
Back tilt range:	(-15°) - 90°	(-18°) - 62°	(-18°) - 62°
Seat tilt range:	0° - 36°	0° - 36°	N/A
Net weight:	150 kg / 330 lbs	125 kg / 276 lbs	100 kg / 220 lbs
Patient capacity:	250kg / 551 lbs	210 kg / 465 lbs	170 kg / 375 lbs
Motor hand control:	•	<i>Optional</i>	<i>Optional</i>
Motor foot control:	N/A	•	•
Patient arm rests:	•	•	•
Detachable side rail:	•	N/A	N/A
Heavy duty Rissler leg rests:	•	•	•
Seat cushion with 170mm cutout:	N/A	•	•
Seat cushion w/o cutout (Non cutout mattress):	•	•	<i>Optional</i>
Fold-up footrests (Act as extension cushion):	•	•	<i>Optional</i>
Extension cushion:	N/A	<i>Optional</i>	<i>Optional</i>
Puzzle piece extension cushion (Fits into seat cutout):	N/A	<i>Optional</i>	<i>Optional</i>
Paper roll holder:	N/A	•	•
Neck pillow:	N/A	•	<i>Optional</i>
Plastic funnel:	•	•	•
Cysto pan:	<i>Optional</i>	<i>Optional</i>	<i>Optional</i>
IV pole:	<i>Optional</i>	<i>Optional</i>	<i>Optional</i>
Examination lamp:	<i>Optional</i>	<i>Optional</i>	<i>Optional</i>

ACCESSORIES

*more options available

FULL RANGE OF ACCESSORIES FOR THOSE WHO WANT MORE

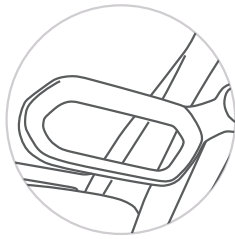

Arm rests: Easy access to the patient from each side; creates a safety barrier when chair is in the table position



Leg rests: Swiveling leg rests to help patient positioning



Fold up footrests: Hydraulic piston helps switch from footrests to extension cushion

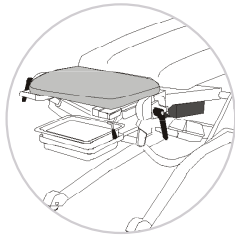

Seat cushion without cut-out:
To convert it into a flat examination table



Puzzle piece: Fits into seat cushion cut-out to produce one continuous surface

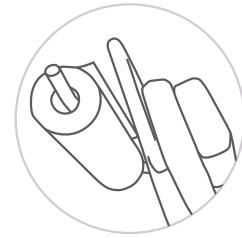

Paper towel holder: Convenient placement for immediate access, it is combined with the manoeuvring handle

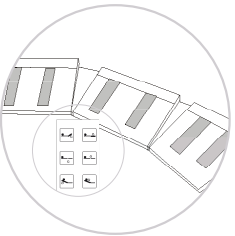

Motor control: Foot-plate and hand-held motor controls to adjust patient position

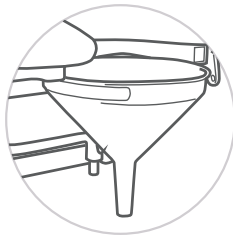

Funnel: For voiding while in procedure chair

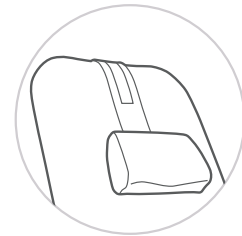

Neck pillow: Enhances patient comfort



Lamp: To enhance the examination procedure

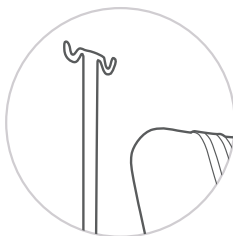

IV Pole: Allows IV bag, pressure transducers & accessories to be mounted on chair for convenience

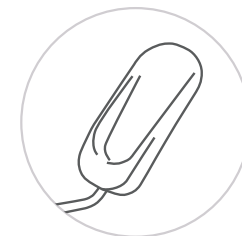

Foot Plates: Convenient for function and comfort

ACCESSORIES

SONESTA PROCEDURE & EXAMINATION CHAIRS

- Versatile
- Mobile
- Enhance patient comfort
- Easy access for elderly and disabled
- Infinite adjustments
- One touch movement locking mechanism for precise positioning (S3)
- Unique radiolucent 6210 model

⁽²⁾ George A. Kuchel, Catherine E. DuBeau. American Society of Nephrology-2009. Geriatric Nephrology Curriculum

References:

⁽³⁾ Lajiness M, Quallich S. The Nurse Practitioner in Urology. Springer; 2016.

⁽¹⁾ United Nations, Department of Economic and Social Affairs, Population Division (2015). World Population Ageing 2015 (ST/ESA/SER.A/390)



Distributed by LABORIE:

USA:

Tel.: 800 522 6743

Email: usmarketing@laborie.com

EUROPE/INTERNATIONAL:

Tel.: +31 53 4803700

Email: info@laborie.com

HEADQUARTERS:

Tel.: +1 905 612 1170

Email: marketing@laborie.com



www.laborie.com

SON-BRU-01-V03-EN-US-PRC-018878